



## SLIDE RAIL SHORING SYSTEM



## Who is GME?

As an industry pioneer since the 1960's, GME quickly took a leadership position in product design and industry development. Since the beginning, GME has lead the industry in product development, innovation and effectiveness.

GME is the producer of the world's most complete line of trench shoring and shielding equipment. The products we offer include:

- Hydraulic Shoring
- Steel Trench Shields
- Aluminum Trench Shields
- Modular Aluminum Trench Shields (Lite-Shield™)
- Slide Rail Shoring Systems
- Hydraulic Bracing Systems (MD Brace)

Through our extensive distribution network, our products can be found on a countless number of job sites around the globe.

Our original facility in Union City, Michigan has expanded over the years to meet the growth demands of the industry. Currently we have four plants dedicated to trench shield and trench shoring production, three located in Union City, Michigan and one located in Ft. Worth, Texas. GME has a sales force that offers over 100 years of collective experience in the trench shoring and shielding industry. With this combined knowledge, GME is able to provide our customers with the solutions they need to get their projects completed.

With a dedicated Research and Development team, including an in-house Registered Professional Engineer, GME is able to continually improve upon our products and product selection, proving that GME is the industry leader in product innovation.

If you have an upcoming project and would like to see how GME can assist you, or if you would like more information about GME and our products, please feel free to contact us at 800.248.2054 or on the web at [www.gme-shields.com](http://www.gme-shields.com).



# Slide Rail Shoring System

What is a Slide Rail Shoring System? Why use it and where to use it?

## What is Slide Rail?

The GME|E+S Slide Rail Shoring system is a durable, modular, dig and push style component shoring system that allows users to push the system in place while digging the excavation to depth. Designed with the contractor in mind, the components of our Slide Rail Shoring system allow contractors to use lighter, more common machines during installation and removal than those that would be required to do the same project using tight sheeting or trench shields.

## Why use Slide Rail?

The GME|E+S Slide Rail Shoring system is engineered to keep workers safe and save contractors time and money. When compared to traditional tight sheeting, sloping or complex trench shield assemblies, a properly engineered Slide Rail Shoring system:

- Controls ground subsidence
- Provides more clearance than standard trench shields
- Minimizing site restoration cost
- Enables smaller, common size excavators
- Decreases the overall installation and removal time of the system

## Where to use Slide Rail?

With its modular, flexible, component design, the GME|E+S Slide Rail Shoring system is versatile enough to be used on a variety of job sites. These include:

- Tank installations
- Bore pits
- Pump stations
- Cast-in-place
- Linear pipeline runs
- Restricted areas (downtowns, industrial sites)
- Poor soil conditions
- Vibration sensitive areas (near hospitals, adjacent buildings)
- Near rail road tracks
- Soil remediations
- And many more...



4-sided system next to a building



Linear system used for a large vault



Multiple bay system using the Weldment

# Main Components

Consisting of four (4) main components; panels, corner rails, linear rails, and strut carts, the GME|E+S Slide Rail System is easily assembled to provide workers with a safe working area.



## Panels

Similar in look to trench shields, the Slide Rail Panels are engineered and built to withstand the most challenging job site conditions. Standard sizes are available from 4' to 8' in height with lengths up to 32'. Custom sizes are available to fit any job specific need.



## Corner Rails

Designed to be used at the corner of a three or four sided system, the Corner Rails allow Slide Rail Panels to be connected at right angles. Available in multiple lengths.



## Linear Rails

Similar in design to Corner Rails, the GME|E+S Linear Rails enable multiple bay systems. Available in standard, medium, and heavy-duty models.



## Strut Carts

Used in conjunction with the Linear Rails as spreaders to help maintain the system stability. Shown with vertical supports, which are recommended for widths greater than 8'. Multiple styles are available to suit job site needs.

# GME|E+S Slide Rail Advantages

Every Slide Rail Shoring System on the market is able to provide users with a safe working space to complete the project. What sets the systems apart from each other is the key between completing the project on-time and under budget or not.



## Open Track Design

The open track design allows panels to be swung into place at ground level, instead of requiring a larger machine to lift the panels to the top of the rails for installation. Additionally, the open track design removes the potential interference of overhead obstructions, such as power lines, during system installation and removal. This enables a quicker installation and removal along with the use of a smaller machine for installation.

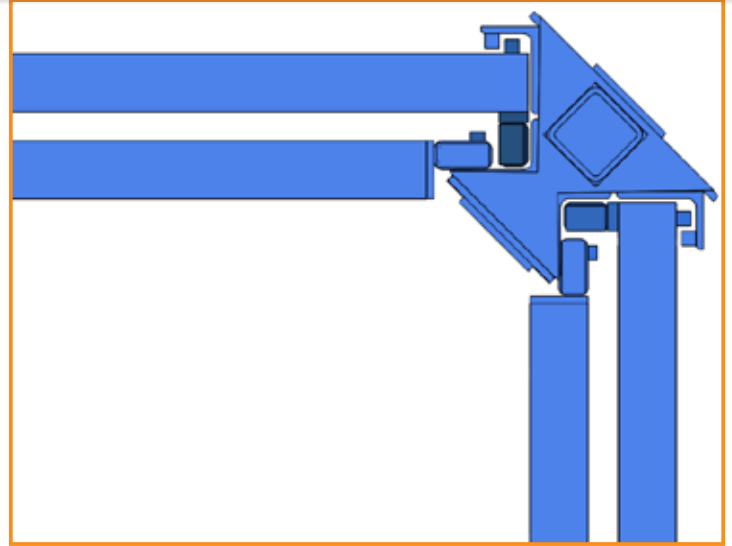

## Unique Strut Carts

Used in conjunction with the Linear Rails, the Strut Carts feature an exclusive floating double roller bearing that assures constant support and uniform load bearing. This allows the strut carts to easily adjust positioning to accommodate job site requirements.



## Long Panels

Longer, engineered panels (up to 32' long!) enable the GME|E+S Slide Rail Shoring systems the ability to eliminate the need for Linear Rails and Strut Carts on certain projects. Saving time and money compared to similar systems.

# General Installation Instructions

Instructions shown are meant to illustrate general assembly only. Each Slide Rail project is unique and may require a slightly different installation procedure. Please contact GME or your local GME Dealer with questions regarding your specific project installation procedures.

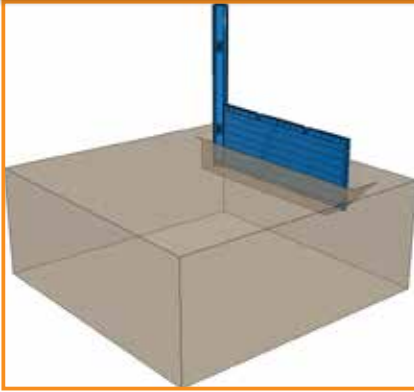

**Step 1**  
Dig pilot cut (3'-4') and place first outer panel and corner rail. Making sure to backfill against outer panel enabling it to stand in place.

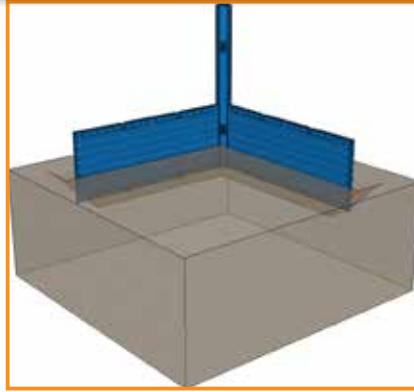

**Step 2**  
Continue pilot cut to set second outer panel. Creating a right angle. Making sure to backfill against outer panel enabling it to stand in place.

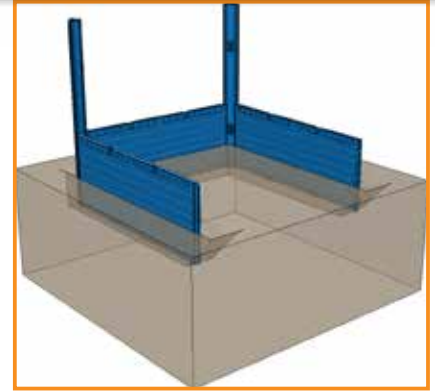

**Step 3**  
As pilot cut continues, place second corner rail and third outer panel. Making sure to backfill against outer panel enabling it to stand in place.

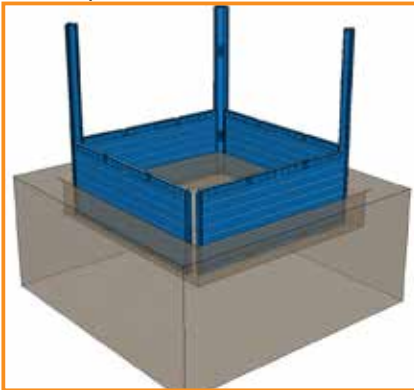

**Step 4**  
Continue pilot cut to place last outer panel.

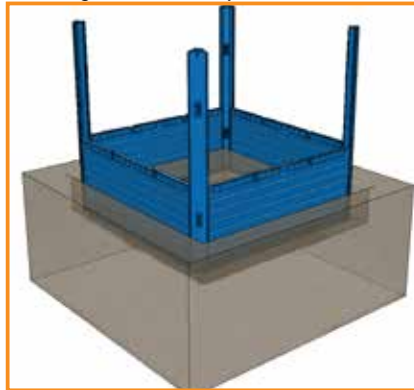

**Step 5**  
Install last corner rail.

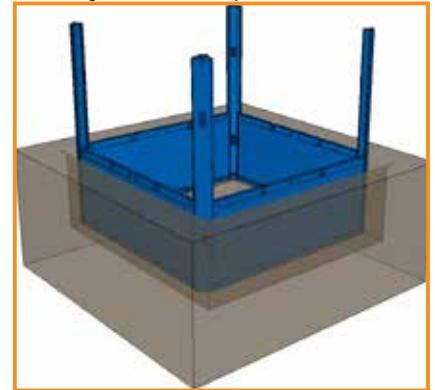

**Step 6**  
Dig inside system, as depth increases, push panels and rails down to depth.

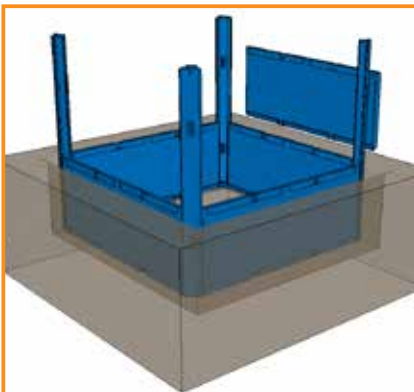

**Step 7**  
As depth increases, install inner panels.

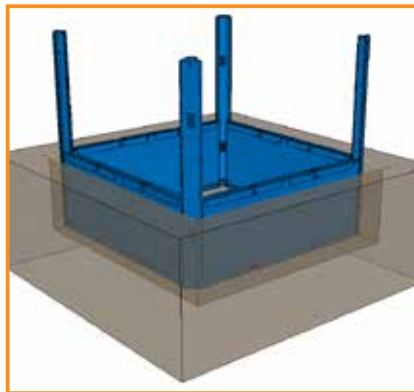

**Step 8**  
Install all needed inner panels.

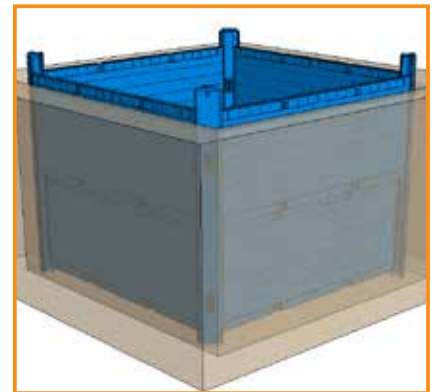

**Step 9**  
Continue to dig inside of system until desired depth is achieved. Push inner panels and rails down as depth increases.

# Slide Rail Configurations

## 4-Sided & Multiple Bay Systems



### 4-Sided Systems

Providing complete protection on all sides, 4-sided systems are ideal for the installation of pump stations, large manholes, and cast-in-place structures. Installed and removed with relative ease, 4-sided systems are can used in restricted spaces, including between and inside of buildings.



### Multiple Bay Systems

A variation of the 4-sided application is a multiple bay system. Becoming more and more popular, multiple bay systems are ideal for the installation and removal of underground fuel tanks, cast-in-place projects, as well as boring and receiving pits.

# Slide Rail Configurations

## Linear Systems



### Linear Systems

With the GME|E+S Slide Rail Shoring system, linear systems are able to be installed quickly and easily with the open track design. Excellent for long pipe runs, linear systems are designed to allow the greatest amount of work to be done, while preserving a safe work space and stability of adjacent buildings and structures.



### Linear Systems

The GME|E+S Slide Rail Shoring system is able to be used in a variety of different soils types and conditions. Linear systems are especially useful for projects adjacent roadways and projects that require large pipe runs. The system is capable of being engineered for use with the GME hydraulic shoring system, to enable multiple pipes at multiple depths.

Job site photos are strictly intended for general product information only and may not comply with all applicable safety standards. Always refer to manufacturers' specific tabulated data, O.S.H.A. 29 CFR 1926 Subpart P for excavations, and all applicable safety standards prior to each use.





### Clearspan Systems

For larger projects such as, cast-in-place and multiple tank installations, the GME|E-S Slide Rail Shoring system can provide the solution. Using external walers and tiebacks, the internal strut carts are able to be completely removed to provide an unobstructed working area while keeping the size of the excavation to an absolute minimum.

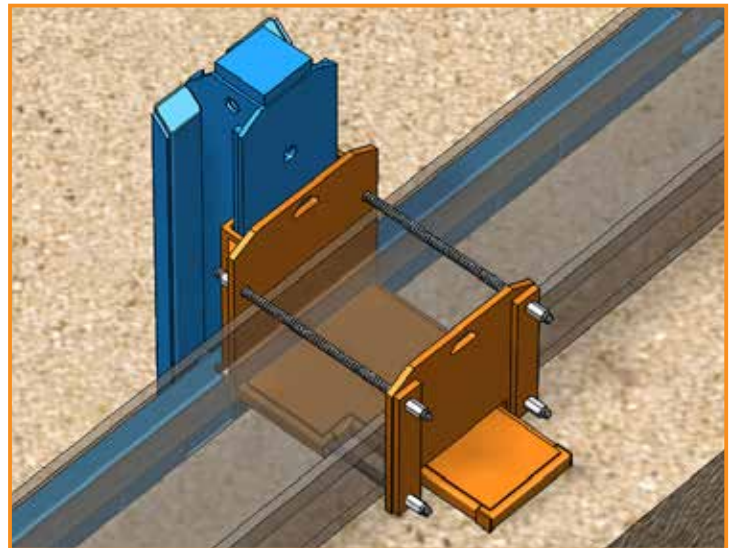

### Tieback System

Using the tieback system, all internal strut carts are able to be removed safely from a system. As opposed to other systems, once the tiebacks are in place the strut carts do not need to be replaced to remove the system, saving both time and money in removing this system.

# Slide Rail Configurations

## Clearspans - continued



### Hybrid Clearspan System

The combination of the MD Brace style rings and Slide Rail Shoring system provides users the best of both worlds. The adjustability of the bracing system with the non-vibratory installation and removal of the GME|E+S Slide Rail Shoring system. The Hybrid Clearspan system, with its internal and external supports eliminates the need for sacrificial beams and strut carts, saving time and money on the installation of the strut carts and purchasing of the sacrificial beams.



### Octagon Slide Rail System

Specifically designed for multiple tank installation projects, the GME|E+S Octagon Slide Rail Shoring system **eliminates** the need for external walers, tiebacks, and sacrificial beams while still providing the vertical clearance needed to properly install the tanks.



## Sheeting Guide System

Used in tandem with a the GME|E+S Slide Rail Shoring system, there are 3 different models; standard duty – using the **NEW** GME overlap sheeting, medium duty – using 4" thick sheeting elements, and the heavy-duty – using 6" thick sheeting elements. All three models are designed to be used without a waler.



## Weldment Guide

Used on existing GME|E+S Slide Rail Panels, the Weldment Guide allows the panels to act as both a slide rail panel and a sheeting guide. The Weldment Guide can be designed to accommodate several different sheeting profiles. Ideal for projects with utilities and pipes toward the bottom of the excavation.



## Guard Rail System

Certified by a Registered Professional Engineer to meet O.S.H.A. fall protection standards, the GME Guard Rail system is available in a standard duty model – using common 2" x 4" boards as railing and a heavy duty model – featuring a wire mesh design for added safety.

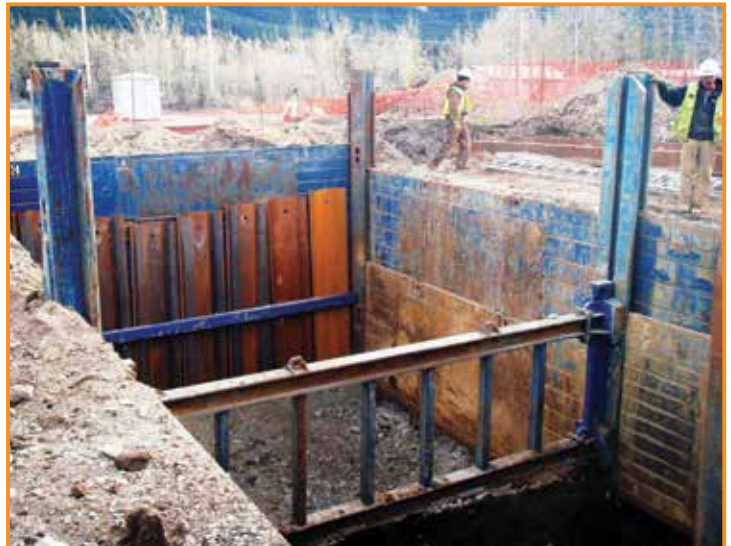

# PRODUCER OF THE WORLD'S MOST COMPLETE LINE OF TRENCH SHORING & SHIELDING EQUIPMENT

Steel Shields



Lite Shields



Height Adapters



AEX Shields



MD Brace System



Hydraulic Shoring



Bedding Boxes



Hydraulic Shields



Exit Grids



Port-a-Bridges

